



## Technical Performance

# LS Cast Resin Transformers

50kVA Through 15,000kVA  
Primary Voltage: 2.3kV Through 36kV  
Secondary Voltage: 120V Through 24kV



# LS Cast Resin Transformer

## Introduction

Great progress has been made in the development and improvement of distribution transformers over the last decades.

The application of high quality insulation material and suitable selection of the coil structure for high stress have contribute to the development of LS CAST RESIN Transformers.

The LS CAST RESIN Transformer has succeeded in combining the advantage of oil-filled and conventional dry type transformers, which are fabricated with an epoxy resin. The windings are completely embeded under vacuum conditions. This casting method makes it possible to assure void-free epoxy penetration of both the inner layer and turn to turn insulation.



### CONTENTS

Applications .....	4
Feature .....	5
Construction .....	6
Specification .....	7
Technical Data (IEEE Standard) .....	9
Technical Data (IEC Standard) .....	11
Manufacturing Process .....	14
Quality Assurance .....	15
Ordering Sheet .....	16

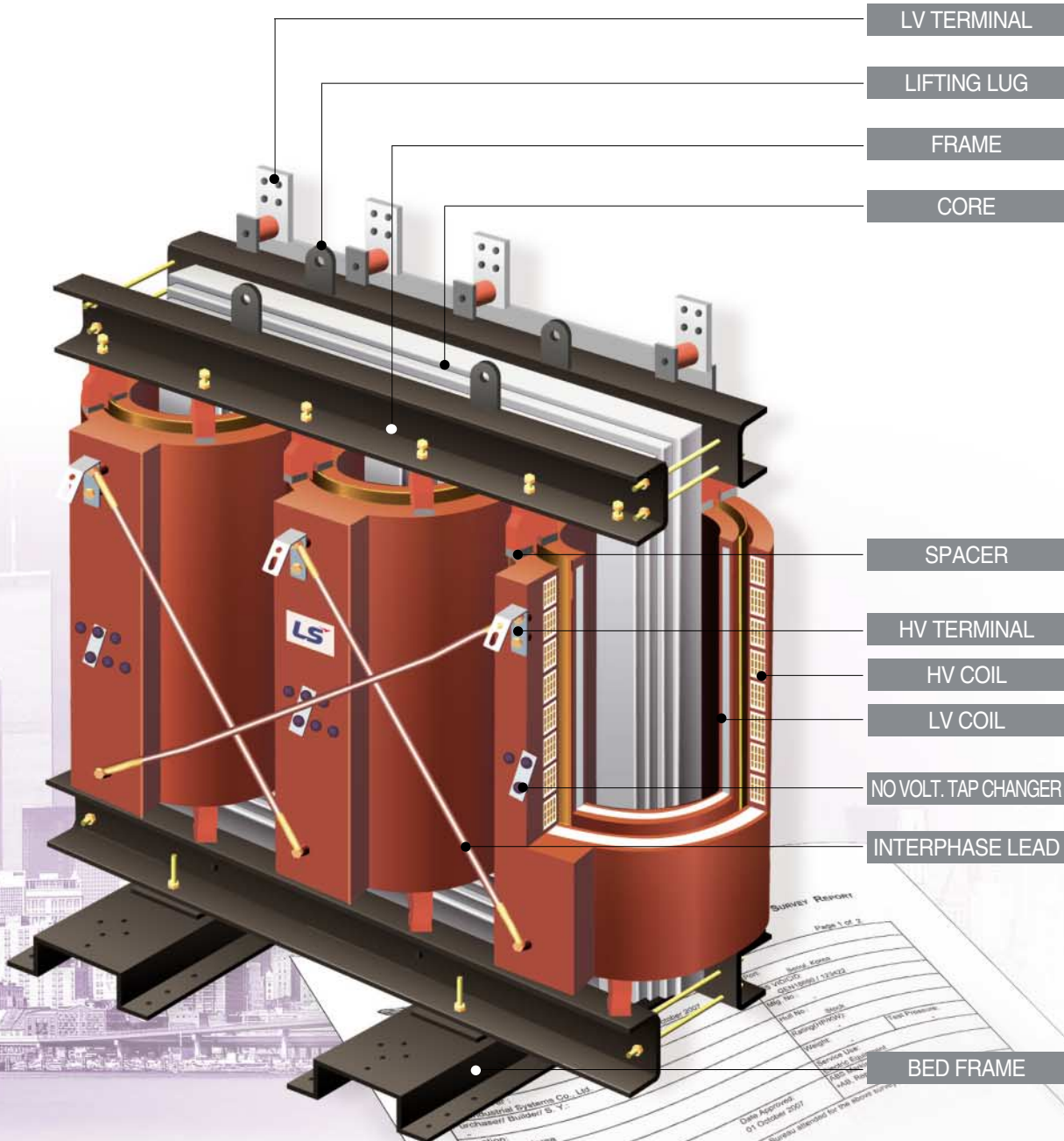

Survey Report  
Page 1 of 2

Client: LSIS Co., Ltd.  
 Location: Cheongju, Korea  
 Serial Number: 20092502  
 Material Test Report No.: 277358  
 Task No.: 277358

Date Approved: 01 October 2007

THIS IS TO CERTIFY that the undersigned Surveyor to the Bureau selected for the above survey

One(1) set of three(3) phase dry type transformer  
 Capacity: 300 KVA  
 Rated voltage & Frequency: 440/220, 60Hz  
 Insulation Class: F

The following tests were carried out and considered satisfactory

1. Voltage ratio test, phase relation and polarity test.
2. Dielectric strength test
  - Primary windings @ 600V x 60Hz for 60 seconds
  - Secondary windings @ 660V x 60Hz for 60 seconds
3. Secondary high voltage test and winding resistance measurement
4. Insulation resistance test @ 40V x 600Hz for 15 seconds
5. No load test, load test & impedance voltage measurement
6. Reviewed Temperature rise test report

K. Y. Yu, Surveyor, American Bureau of Shipping



# Applications

LS CAST RESIN Transformers can be used in various fields. Here are just a few possible applications.

- Indoor and outdoor unit substations
- Off-shore flatforms
- Commercial buildings
- Hospitals
- Shopping centers
- Water supplies
- Traction systems
- SCR Power supplies
- Ships
- Power Plants

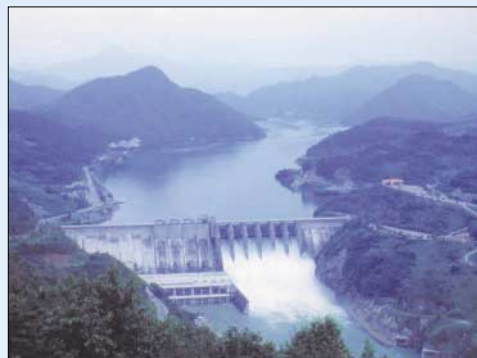

## Environmentally safe

LS CAST RESIN Transformers will not emit oil or toxic gases into the atmosphere. Therefore, they do not pollute the environment and are strongly recommended as a replacement for askarel(PCB)-filled transformers.

## Moisture proof

The complete casting of coils under vacuum prevents the penetration of moisture into the winding.

Therefore, it is suitable for both storage and operation in harsh environment and is capable of being switched on immediately after such storage without pre-drying.

## No partial discharge

There is no possibility of partial discharge in LS CAST RESIN Transformers.

Whole core & coil is tested to guarantee the life expectancy of the insulation system.

LS CAST RESIN Transformers are free of partial discharge at least up to 1.3 times of the rated voltage.

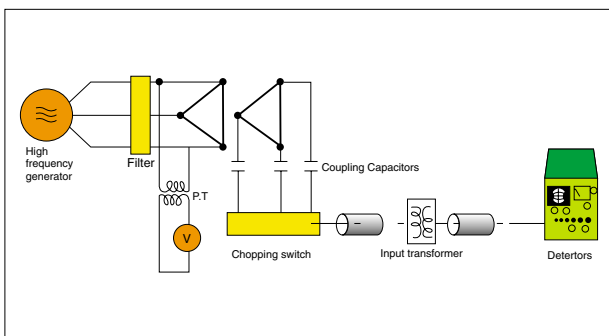

## Low noise

The coating of the core with an epoxy resin have lead to an appreciable noise reduction. Noise is also reduced due to the sound suppressing effect of the step lap cutting.

## High overload capability

Based on the high thermal time constant factor of the windings, LS CAST RESIN Transformers can be overloaded for a short duration considerably higher than oil-immersed transformers. It has a greater capability to withstand sudden high overloads such as might be encountered in heavy traction applications.

## High impulse strength

LS CAST RESIN Transformers are very resistant to impulse voltage.

Impulse withstand levels to 200kV are available because of careful design and special structure.

## Maintenance free

Maintenance is almost completely eliminated. No checking of liquid level and no dielectric test for moisture absorption is required.

Due to the smooth coil surface, heavy dirt and dust build up is eliminated even under the worst circumstances.

The recommended routine maintenance is an occasional visual inspection.

## Fire resistant

LS CAST RESIN Transformers have a very excellent characteristic of self fire-extinguishing and fire resistance.

So there would be no fear of spread of fire even if fire took place around the electricity room.

LS CAST RESIN Transformers take pride in the ability to offer a wide variety of designs and configurations necessary to satisfy customer needs. Computer and CAD/CAM systems are used for quick and accurate design and manufacture to meet specific customer requirements.

## ➤ CORE & FRAME

The core is made of highest quality, cold rolled, grain-oriented, silicon steel and step lap joint.

Three legs of the core are arranged in a single plane and interconnected with a yoke.

The legs are circular structure and are carefully interlaced with stepwise arranged yokes.

The core is mitred at a 45 degree angle and care-fully stacked and pressed to obtain low loss, exciting current and noise.

The core is insulated on both side of each lamination and protected against corrosion by a resin coating and grounded in frame.

The frame consists of upper and lower steel channels. It holds the core and coil together.

To protect against corrosion, all steel parts are coated with epoxy paint.

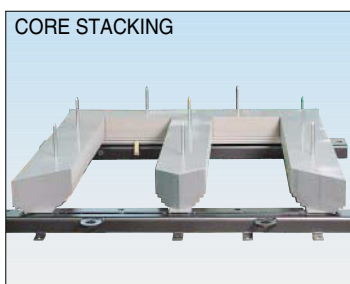
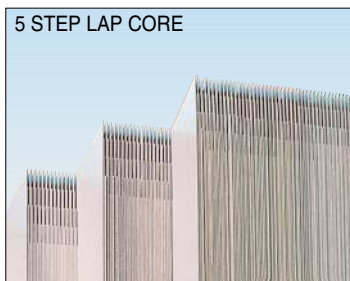

## ➤ HV & LV Coils

### ● HV COIL (Vacuum Cast type)

- HV COIL Vacuum Cast in epoxy with a mold.
- Aluminum / Copper conductor.



### ● LV COIL (Encapsulated Cast type)- standard

- LV COIL Encapsulated after winding with prepreg layer insulation.
- Aluminum / Copper conductor.



### ● LV COIL (Vacuum Cast type)- optional

- LV COIL Vacuum Cast in epoxy with a mold.
- Aluminum / Copper conductor.



Conductor insulated with a high grade is used in the winding construction.

Turns are arranged in multiple sections and layers in order to decrease transient maximum voltages. High voltage windings are cast in a mold under vacuum, using a computer controlled mixing and vacuum casting process.

So there is no void in the coils. The windings are fiberglass reinforced to provide additional mechanical strength.

After assembly, all HV coils are partial discharge tested to verify void free in the coils.

## Specification Data

LS CAST RESIN Transformers are normally available with specification as follows:

- **Rated voltage**  
 HV COIL : up to 36kV  
 LV COIL : up to 600V  
 \* Dual voltage coils can also be supplied.
- **Standard Tapping range** :  $\pm 2.5\%$ ,  $\pm 5\%$   
 \* Other ratings are available by request
- **Power capacity**  
 Single phase : 20 ~ 2,000kVA  
 Three phase : 50 ~ 15,000kVA
- **Frequency** : 50Hz, 60Hz  
 \* Other frequency is available by request
- **% Impedance voltage**  
 IEC STD. : 4.0 ~ 8.0%  
 IEEE STD. : 5.75 ~ 8.0%  
 \* Other % impedance voltages are available.
- **Connections**  
 HV COIL : Delta  
 LV COIL : Star with neutral point  
 \* Other connections are available to meet requirement.
- **Temperature class (According to IEC 60076-11)**  
 HV COIL and LV COIL : F CLASS  
 \* H class coils are available by request.
- **Conductor**  
 Aluminum (standard)  
 Copper (optional)
- **Noise Level (according to NEMA Std.)**  
 500kVA - 60dB  
 750kVA - 64dB  
 1000kVA - 64dB  
 1500kVA - 65dB  
 2000kVA - 66dB  
 2500kVA - 68dB  
 \*Noise reduction TRs are available by request.

## Standards

LS CAST RESIN Transformers confirm to the requirements of IEC 60076-11 (2004).

However we can also meet the requirements of the following standards, upon request.

- **IEEE C57.12.01 (2005)**  
 General requirement for dry-type distribution and power transformers.
- **CSA Standard C9-02 (R2007)**  
 Dry type transformers.
- **HD538.1,2,3(1995)**  
 3 Phase Dry type distribution transformers.  
 50Hz from 100kVA to 2500kVA
- **BS 7806 (1995)**  
 Dry type Power transformers
- **AS 2374 (1982)**  
 Power transformers  
 \* Transformers for rectifier applications and other special purposes can be supplied according to the client's specification.

## Certificates



**CESI** 

   **KEMA** 

ISO14001, ISO 9001

## Accessories

### ● Normally provided accessories

- HV & LV terminals
- Lifting lugs
- Grounding terminals
- Name plate
- Danger label
- Tap terminal link
- Protection cap for tap terminal
- Anti-vibration pads

### ● Optional accessories

- Wheels
- Cooling fan & temp. controller
- Digital thermometer & PT 100 OHM (1 Phase)
- Digital thermometer & PT 100 OHM (3 Phase)
- Enclosure

HV terminals



LV terminals

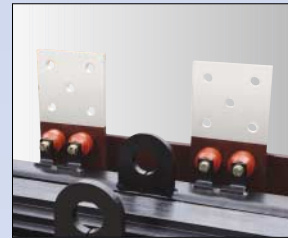

Lifting lugs



Grounding terminals



Danger label



Tap terminal link



Protection cap



Anti-vibration pads



Wheels



Cooling fan



Temperature controller



Enclosure





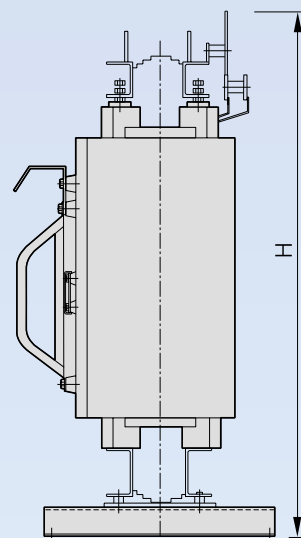
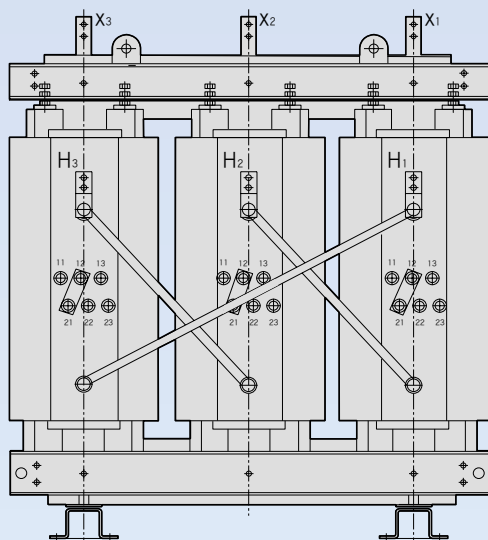
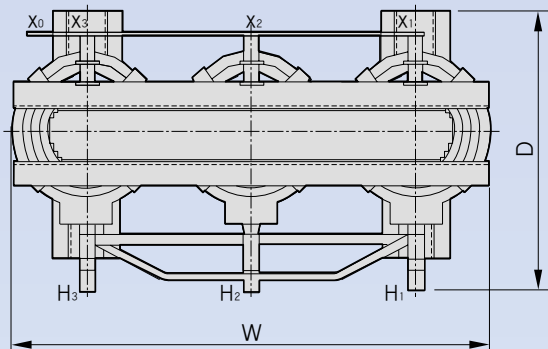

IEEE C 57.12.01 (2005)  
 F CLASS, 90K TEMP.RISE, 60Hz  
 5kV CLASS, 75kV BIL

Rated Power (kVA)	Impedance Voltage (%)	No Load Loss (W)	Load Loss (W)	Efficiency (%)			Dimension (mm)			Weight (kg)
				100% Load	75% Load	50% Load	Width (W)	Depth (D)	Height (H)	
500	5.75	1,300	6,000	98.5	98.7	98.8	1,290	800	1,430	1,350
750	5.75	1,750	8,000	98.7	98.8	98.9	1,380	900	1,600	1,790
1,000	5.75	2,300	8,600	98.9	99.0	99.1	1,510	1,000	1,710	2,350
1,500	5.75	3,150	10,200	99.1	99.2	99.2	1,690	1,000	1,790	3,250
2,000	5.75	3,900	12,500	99.1	99.2	99.2	1,805	1,200	2,050	4,150
2,500	5.75	4,900	13,500	99.2	99.3	99.3	2,015	1,200	2,100	5,150

\* Other kVA is available according to request.

# Technical Data (IEEE Standard)

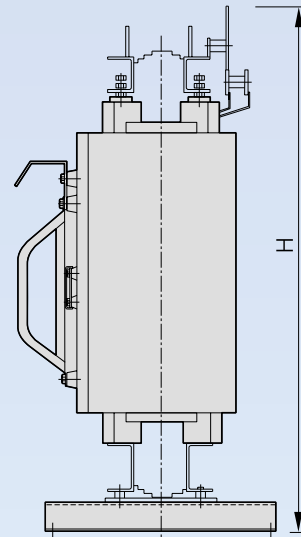
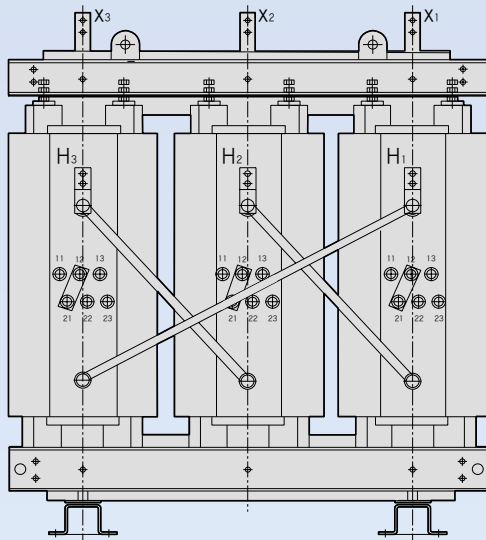
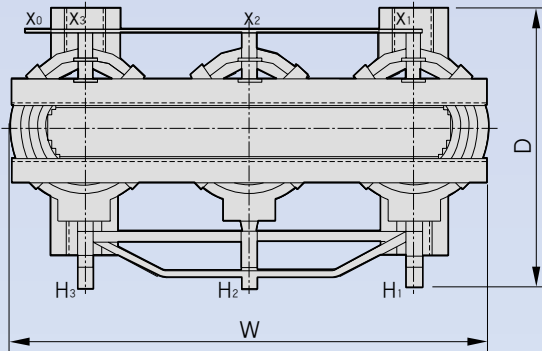

IEEE C 57.12.01 (2005)  
 F CLASS, 90K TEMP.RISE, 50Hz  
 15kV CLASS, 110kV BIL

Rated Power (kVA)	Impedance Voltage (%)	No Load Loss (W)	Load Loss (W)	Efficiency (%)			Dimension (mm)			Weight (kg)
				100% Load	75% Load	50% Load	Width (W)	Depth (D)	Height (H)	
500	5.75	1,550	5,600	98.5	98.7	98.8	1,390	900	1,640	1,600
750	5.75	2,150	6,700	98.8	98.9	98.9	1,495	920	1,700	2,050
1,000	5.75	2,700	8,400	98.9	99.0	99.0	1,660	1,005	1,780	2,650
1,500	6.00	3,600	9,100	99.1	99.2	99.2	1,840	1,025	1,885	3,650
2,000	6.00	4,550	13,300	99.1	99.2	99.2	1,945	1,200	2,140	4,450
2,500	8.00	5,100	15,000	99.2	99.2	99.3	2,160	1,200	2,160	5,250

\* Other kVA is available according to request.

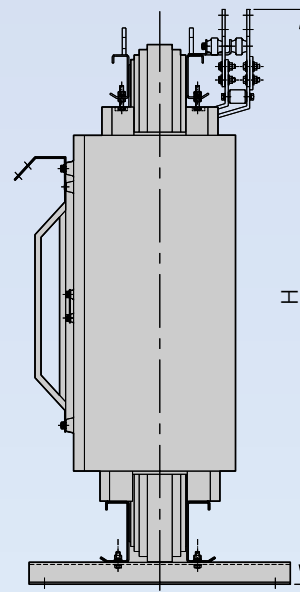
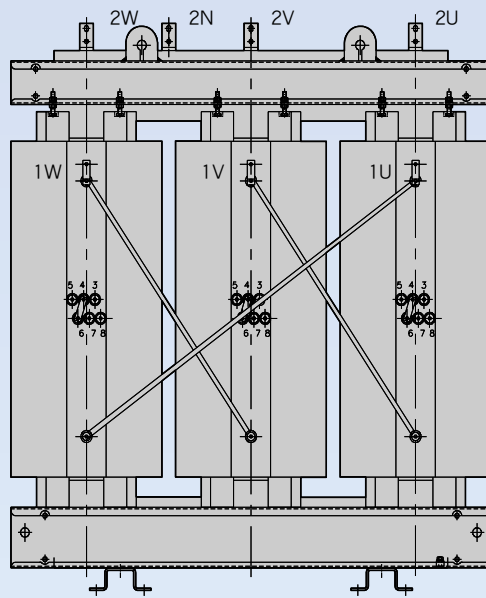
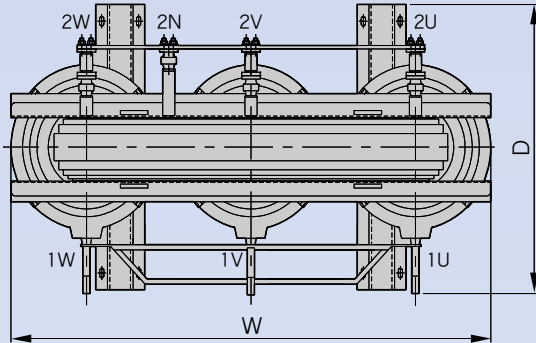

Standard : IEC 60076-11 (2004)  
 F CLASS, 100K TEMP.RISE, 50Hz  
 12kV CLASS, 75 BIL

Rated Power (kVA)	Impedance Voltage (%)	No Load Loss (W)	Load Loss (W)	Efficiency (%)			Dimension (mm)			Weight (kg)
				100% Load	75% Load	50% Load	Width (W)	Depth (D)	Height (H)	
400	4.0	1,150	4,900	98.5	98.7	98.8	1,220	800	1,430	1,300
630	6.0	1,500	7,300	98.6	98.8	98.9	1,400	900	1,570	1,750
1,000	6.0	2,000	10,000	98.8	98.9	99.1	1,520	1,000	1,700	2,400
1,250	6.0	2,500	12,500	98.8	98.9	99.1	1,700	1,000	1,780	3,000
1,600	6.0	2,800	14,000	98.9	99.1	99.2	1,750	1,000	1,820	3,400
2,000	6.0	3,700	16,500	99.0	99.1	99.2	1,805	1,200	2,040	4,200
2,500	6.5	4,300	21,000	99.0	99.1	99.2	1,985	1,200	2,150	5,000
3,150	7.0	6,200	22,000	99.1	99.2	99.2	2,220	1,205	2,190	6,250

\* Other kVA is available according to request.

# Technical Data (IEC Standard)

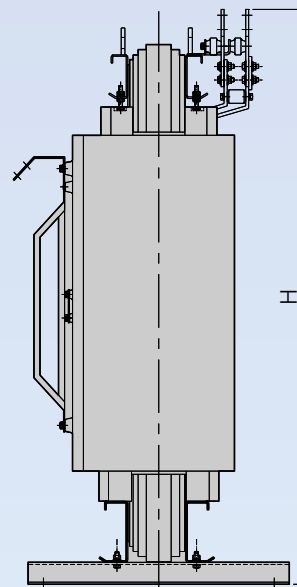
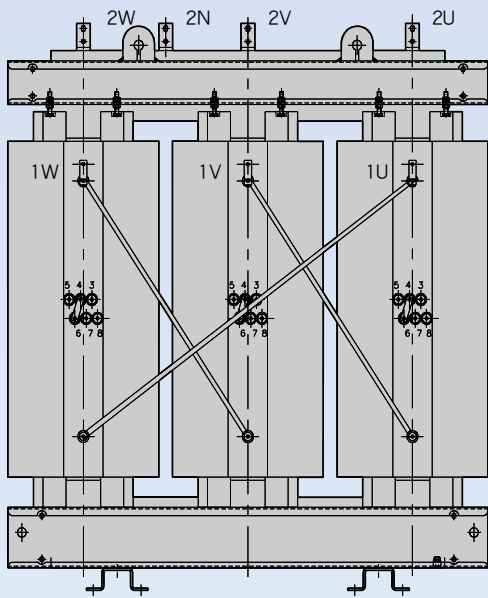
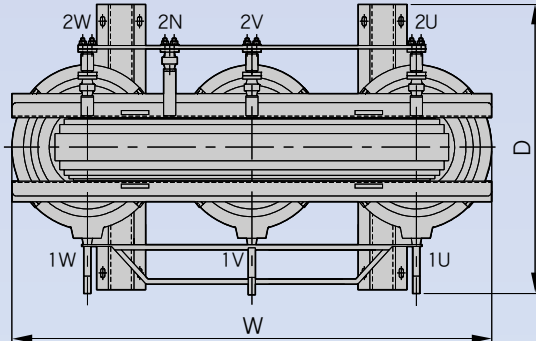

Standard : IEC 60076-11 (2004)  
 F CLASS, 100K TEMP.RISE, 50Hz  
 24kV CLASS, 125 BIL

Rated Power (kVA)	Impedance Voltage (%)	No Load Loss (W)	Load Loss (W)	Efficiency (%)			Dimension (mm)			Weight (kg)
				100% Load	75% Load	50% Load	Width (W)	Depth (D)	Height (H)	
400	6.0	1,200	5,500	98.3	98.5	98.7	1,360	840	1,500	1,400
630	6.0	1,650	7,800	98.5	98.7	98.8	1,450	905	1,670	1,850
1,000	6.0	2,300	11,000	98.6	98.8	99.0	1,675	1,000	1,810	2,700
1,250	6.0	2,850	13,000	98.7	98.9	99.0	1,750	1,010	1,860	3,100
1,600	7.0	3,100	16,000	98.8	99.0	99.1	1,810	1,200	2,060	3,650
2,000	7.5	4,050	17,500	98.9	99.0	99.1	1,950	1,200	2,120	4,450
2,500	7.5	5,000	21,000	98.9	99.1	99.1	2,155	1,200	2,190	5,400
3,150	7.5	6,500	22,000	99.1	99.2	99.2	2,305	1,215	2,250	6,600

\* Other kVA is available according to request.



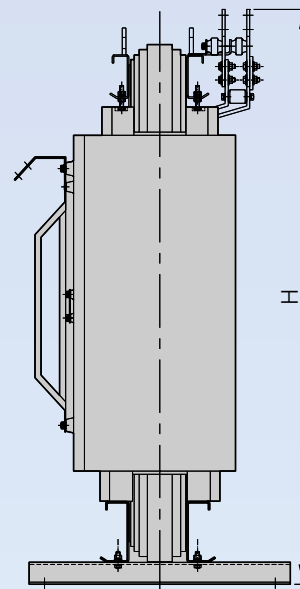
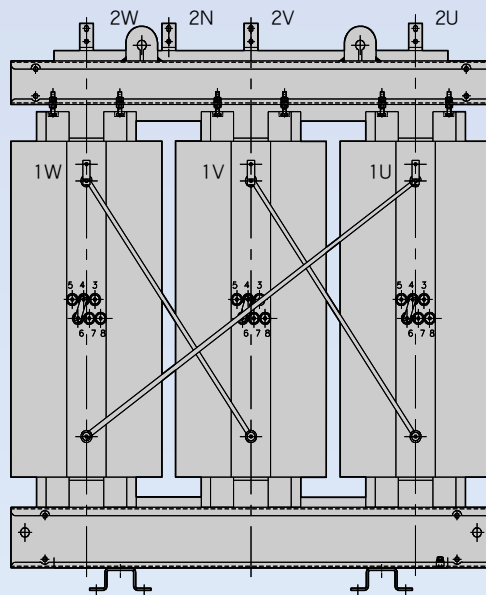
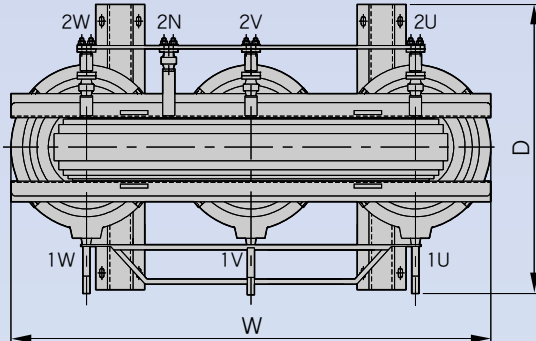

Standard : IEC 60076-11 (2004)  
 F CLASS, 100K TEMP.RISE, 50Hz  
 36kV CLASS, 170 BIL

Rated Power (kVA)	Impedance Voltage (%)	No Load Loss (W)	Load Loss (W)	Efficiency (%)			Dimension (mm)			Weight (kg)
				100% Load	75% Load	50% Load	Width (W)	Depth (D)	Height (H)	
630	6.5	2,200	8,000	98.4	98.6	98.6	1,700	1,105	1,920	2,500
1,000	7.0	3,100	11,500	98.5	98.7	98.8	1,835	1,125	1,980	3,200
1,250	7.0	3,700	14,000	98.6	98.7	98.8	1,850	1,220	2,190	3,700
1,600	7.5	4,200	17,000	98.6	98.8	98.9	2,030	1,250	2,250	4,500
2,000	7.5	5,350	19,000	98.7	98.9	99.0	2,225	1,300	2,330	5,350
2,500	8.5	6,100	20,000	98.9	99.0	99.1	2,440	1,330	2,360	6,400
3,150	9.5	7,400	22,000	99.0	99.1	99.1	2,555	1,350	2,390	7,250

\* Other kVA is available according to request.

# Manufacturing Process

CORE CUTTING



COIL WINDING

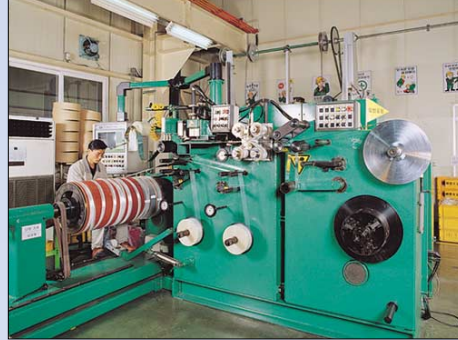

CORE STACKING



CASTING



ASSEMBLY



TEST



## ➤ Routine Test

the following test are made on all transformer.

- Resistance measurements
- Ratio test
- Polarity and phase relation test
- Impedance and load loss
- No load loss and exciting current
- Applied potential tests
- Double induced potential test
- Partial discharge test(below 10 PC)

## ➤ Optional Test

- Impulse test
- Temperature-rise test
 

Temperature-rise test carried out according to the simulated loading method.

  - no load loss
  - load loss

The total temperature rise is calculated in accordance with IEC 60076-11 or IEEE
- Short circuit test
  - 3P 1600kVA Certified by KEMA
- Audible sound level test
  - test by IEC 60076-10
  - LS use Pressure Level (Lp).
$$Lw(A) = Lp(A) + 10 \text{ LOG } S$$

$$S = 1.25 \times H \times P$$

H : Transformer height  
P : Measurement contour perimeter
- Climatic, environmental and fire behaviour classes
  - Certificated at CESI according to IEC 60076-11
  - Fire Behavior Class : F1
  - Environmental Class : E2
  - Climatic Class : C1
  - Class C2 is available

### ROUTINE TEST



### IMPULSE TEST



### SHORT CIRCUIT TEST



### FIRE BEHAVIOR TEST



# Ordering Sheet

Ref. No. : \_\_\_\_\_

Date. : \_\_\_\_\_

## End User and Location :

ITEM	TR.-1	TR.-2	TR.-3	TR.-4
Rated kVA				
Q'ty (sets)				
Rated Voltage(V)	Primary(V)			
	Secondary(V)			
Connection	Primary			
	Secondary			
Phase ( $\phi$ )				
% Impedance (%)				
1. Frequency	<input type="checkbox"/> 50Hz	<input type="checkbox"/> 60Hz	<input type="checkbox"/> Other	
2. Conductor	<input type="checkbox"/> Maker Standard	<input type="checkbox"/> Copper	<input type="checkbox"/> Aluminum	<input type="checkbox"/> Other
3. Primary Taps	<input type="checkbox"/> $\pm 2 \times 2.5\%$	<input type="checkbox"/> $\pm 2.5\%$	<input type="checkbox"/> Other	
4. Applied standard	<input type="checkbox"/> IEC	<input type="checkbox"/> IEEE	<input type="checkbox"/> BS	<input type="checkbox"/> Other
5. Insulation Class				
Primary	<input type="checkbox"/> Maker Standard(155°C)			<input type="checkbox"/> Other
Secondary	<input type="checkbox"/> Maker Standard(155°C)			<input type="checkbox"/> Other
6. Winding Temperature Rise				
Primary	<input type="checkbox"/> Maker Standard	<input type="checkbox"/> 80°C	<input type="checkbox"/> 100°C	<input type="checkbox"/> 125°C <input type="checkbox"/> Other
Secondary	<input type="checkbox"/> Maker Standard	<input type="checkbox"/> 80°C	<input type="checkbox"/> 100°C	<input type="checkbox"/> 125°C <input type="checkbox"/> Other
7. Accessories	<input type="checkbox"/> Digital Thermometer <input type="checkbox"/> Cooling Fans controller <input type="checkbox"/> Cooling fans <input type="checkbox"/> User Spec. (    P    V    Hz) <input type="checkbox"/> Maker Standard.			
8. Protection	<input type="checkbox"/> IP00	<input type="checkbox"/> IP21	<input type="checkbox"/> IP31	<input type="checkbox"/> Other
9. Attached specification ( <input type="checkbox"/> Yes , <input type="checkbox"/> No ) , If "Yes" (Total page :      pages)				
10. Remarks				
1.				
2.				
3.				









## Green Innovators of Innovation



### Safety Instructions

- For your safety, please read user's manual thoroughly before operating.
- Contact the nearest authorized service facility for examination, repair, or adjustment.
- Please contact a qualified service technician when you need maintenance. Do not disassemble or repair by yourself!
- Any maintenance and inspection shall be performed by the personnel having expertise concerned.

LSIS Co., Ltd.

© 2001.4 LSIS Co.,Ltd. All rights reserved.

[www.lsis.biz](http://www.lsis.biz)

### ■ HEAD OFFICE

Korea Gyeonggi-do Anyang-si dongan-gu  
LS-ro 127 (Hogye-dong)  
Tel. (82-2)2034-4887, 4873, 4148  
Fax. (82-2)2034-4648

### ■ CHEONG-JU PLANT

Cheong-Ju Plant #1, Song Jung Dong, Hung Duk Ku,  
Cheong Ju, 361-720, Korea

### ■ Global Network

- **LSIS (Middle East) FZE >> Dubai, U.A.E.**  
Address: LOB 19 JAFZA VIEW TOWER Room 205, Jebel Ali Freezone P.O. Box 114216, Dubai, United Arab Emirates  
Tel: 971-4-886 5360 Fax: 971-4-886-5361 e-mail: jungyongl@lsis.biz
- **Dalian LSIS Co., Ltd. >> Dalian, China**  
Address: No.15, Liaohexi 3-Road, Economic and Technical Development zone, Dalian 116600, China  
Tel: 86-411-8273-7777 Fax: 86-411-8730-7560 e-mail: lixk@lsis.com.cn
- **LSIS (Wuxi) Co., Ltd. >> Wuxi, China**  
Address: 102-A, National High & New Tech Industrial Development Area, Wuxi, Jiangsu, 214028, P.R.China  
Tel: 86-510-8534-6666 Fax: 86-510-522-4078 e-mail: xuhg@lsis.com.cn
- **LSIS-VINA Co., Ltd. >> Hanoi, Vietnam**  
Address: Nguyen Khe - Dong Anh - Ha Noi - Viet Nam  
Tel: 84-4-882-0222 Fax: 84-4-882-0220 e-mail: srjo@lsisvina.com
- **LSIS-VINA Co., Ltd. >> Hochiminh, Vietnam**  
Address: 41 Nguyen Thi Minh Khai Str. Yoco Bldg 4th Floor, Hochiminh City, Vietnam  
Tel: 84-8-3822-7941 Fax: 84-8-3822-7942 e-mail: sbpark@lsisvina.com
- **LSIS Shanghai Office >> Shanghai, China**  
Address: Room E-G, 12th Floor Huamin Empire Plaza, No.726, West Yan'an Road Shanghai 200050, P.R. China  
Tel: 86-21-5237-9977 (609) Fax: 89-21-5237-7191 e-mail: jinhk@lsis.com.cn
- **LSIS Beijing Office >> Beijing, China**  
Address: B-Tower 17FL.Beijing Global Trade Center B/D. No.36, BeiSanHuanDong-Lu, DongCheng-District, Beijing 100013, P.R. China  
Tel: 86-10-5825-6025,7 Fax: 86-10-5825-6026 e-mail: cuixiaorong@lsis.com.cn
- **LSIS Guangzhou Office >> Guangzhou, China**  
Address: Room 1403,14F,New Poly Tower,2 Zhongshan Liu Road,Guangzhou, P.R. China  
Tel: 86-20-8326-6764 Fax: 86-20-8326-6287 e-mail: linsz@lsis.biz
- **LSIS Chengdu Office >> Chengdu, China**  
Address: Room 1701 17Floor, huanminhanjun international Building, No1 Fuxing Road Chengdu, 610041, P.R. China  
Tel: 86-28-8670-3101 Fax: 86-28-8670-3203 e-mail: yangcf@lsis.com.cn
- **LSIS Qingdao Office >> Qingdao, China**  
Address: 7B40,Haixin Guangchang Sheny Building B, No.9, Shandong Road Qingdao 26600, P.R. China  
Tel: 86-532-8501-6568 Fax: 86-532-583-3793 e-mail: lirj@lsis.com.cn
- **LSIS NETHERLANDS Co.Ltd >> Qingdao, Netherlands**  
Address: 1st. Floor, Tupolevlaan 48, 1119NZ,Schiphol-Rijk, The Netherlands  
Tel: 31-20-654-1420 Fax: 31-20-654-1429 e-mail: junshickp@lsis.biz
- **LSIS Gurgaon Office >> Gurgaon, India**  
Address: 109 First Floor, Park Central, Sector-30, Gurgaon- 122 002, Haryana, India

Specifications in this catalog are subject to change without notice due to continuous product development and improvement.